

Mixing valves and actuators



610 - 611 - 612 - 6370 series



01169/17 GB

replaces dp 01169/09



Function

The mixing valves allow the centralisation heating system to be regulated by mixing the boiler outlet water with the return water from the system, in order to obtain the desired flow temperature to the user.

They can be motorized and combined with climatic regulators to send the hot water to the user according to the actual thermal load required, thus respecting the recent energy saving provisions.

Reference documentation

- Instruction sheet 11211921 Digital regulator with functional synoptic for heating and cooling.
- Instruction sheet 18057 Optimiser® digital climate regulator for heating 1520 series.
- Instruction sheet 18075 Optimiser® digital climate regulator for heating and heating/cooling 1520 series.



Product range

610 series	Three-way butterfly threaded mixing valve with manual control	sizes DN 20 (3/4")–DN 65 (2 1/2") F
610 series	Three-way flanged butterfly mixing valve with manual control	sizes DN 50–DN 125
611 series	Four-way butterfly threaded mixing valve with manual control	sizes DN 20 (3/4")–DN 65 (2 1/2") F
611 series	Four-way flanged butterfly mixing valve with manual control	sizes DN 50–DN 125
612 series	Three-way sector threaded mixing valve with manual control	sizes DN 20 (3/4")–DN 65 (2 1/2") F
612 series	Three-way flanged sector mixing valve with manual control	sizes DN 50–DN 125
61202 series	Three-way motorized sector threaded mixing valve, RH version	sizes DN 20 (3/4")–DN 65 (2 1/2")
61201 series	Three-way motorized sector threaded mixing valve, LH version	sizes DN 20 (3/4")–DN 65 (2 1/2")

Code 637002/04	Actuator for mixing valves from 3/4" to 1 1/2" with auxiliary microswitch, RH version	electric supply 230 V (ac) or 24 V (ac)
Code 637002/04	Actuator for mixing valves from 3/4" to 1 1/2" with auxiliary microswitch, LH version	electric supply 230 V (ac) or 24 V (ac)
Code 637001/03	Actuator for mixing valves from 2" to 5" with auxiliary microswitch	electric supply 230 V (ac) or 24 V (ac)

Technical specifications

Materials

Body:	cast iron EN 1561/98 EN-GJL-200
Rotor:	cast iron EN 1561/98 EN-GJL-200
Cover:	aluminium
Bushing:	aluminium
Lever:	PA66GF30
Seals:	EPDM

Performance

Medium:	water, glycol solutions
Max. percentage of glycol:	30%
Max. working pressure:	6 bar
Working temperature range:	2–110°C
Rotor rotation angle:	90°

Threaded connections:	3/4"–2 1/2" F
Flanged connections:	DN 50–DN 125, PN 6 can be coupled with counterflange EN 1092-1

Actuators

Type with 3 contacts, electric supply:	
- codes 637002, 637012, 637001:	230 V - 50 Hz
- codes 637004, 637014, 637003:	24 V - 50 Hz
Power consumption:	
- codes 637002, 637004, 637001, 637003:	3 VA
- codes 637012, 637014:	4,5 VA
Auxiliary microswitch contact rating:	
- codes 637002, 637004, 637001, 637003:	10 (2) A - 250 V (ac)
- codes 637012, 637014:	16 (4) A - 250 V (ac)
Protection class:	IP 42
Operating time:	
- codes 637002, 637004, 637001, 637003:	60 s
- codes 637012, 637014:	180 s
Torque:	
- codes 637002, 637004, 637001, 637003:	15 N·m
- codes 637012, 637014:	35 N·m
Maximum ambient temperature:	55°C
With adapter	

Dimensions

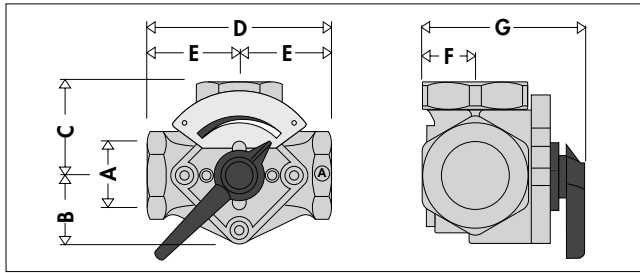

Code	A	B	C	D	E	F	G	Mass (kg)
610005	3/4"	52	65	130	65	40	128	2,8
610006	1"	52	65	130	65	40	128	2,8
610007	1 1/4"	52	70	140	70	40	128	3,1
610008	1 1/2"	52	78	156	78	40	128	3,6
610009	2"	52	75	150	75	40	128	4,6
610020	2 1/2"	66	100	200	100	56	128	8,8

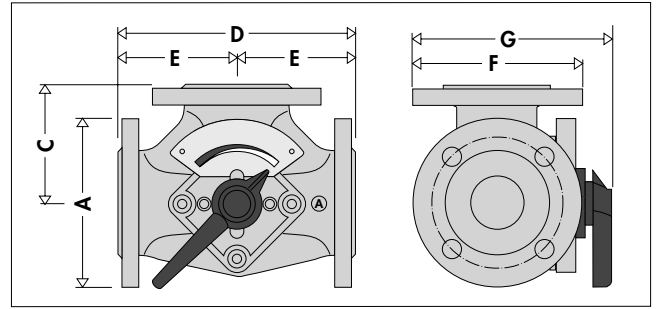

Code	A	C	D	E	F	G	Mass (kg)
610050	DN 50	90	180	90	140	190	7,1
610060	DN 65	100	200	100	160	210	9,8
610080	DN 80	115	230	115	190	240	13,1
610100	DN 100	130	260	130	210	260	20,2
610120	DN 125	145	290	145	240	290	32

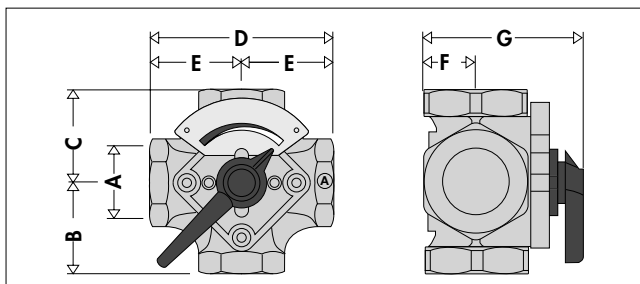

Code	A	B	C	D	E	F	G	Mass (kg)
611005	3/4"	65	65	130	65	40	128	2,9
611006	1"	65	65	130	65	40	128	3
611007	1 1/4"	70	70	140	70	40	128	3,3
611008	1 1/2"	78	78	156	78	40	128	4
611009	2"	75	75	150	75	40	128	5,1
611020	2 1/2"	100	100	200	100	56	158	9,7

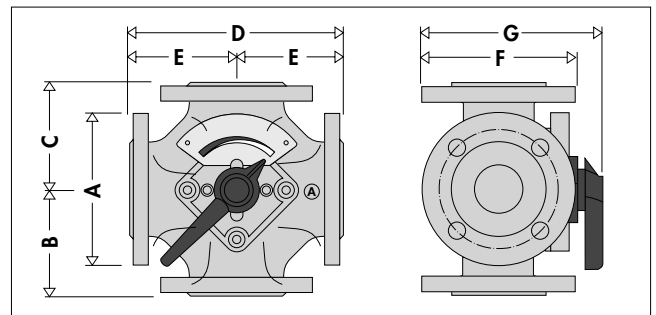

Code	A	B	C	D	E	F	G	Mass (kg)
611050	DN 50	90	90	180	90	140	190	8,3
611060	DN 65	100	100	200	100	160	210	11,6
611080	DN 80	115	115	230	115	190	240	16,4
611100	DN 100	130	130	260	130	210	260	21
611120	DN 125	145	145	290	145	240	290	28

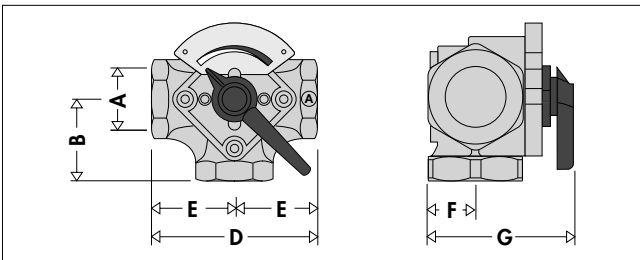

Code	A	B	D	E	F	G	Mass (kg)
612005	3/4"	65	130	65	40	128	2,8
612006	1"	65	130	65	40	128	2,8
612007	1 1/4"	70	140	70	40	128	3,1
612008	1 1/2"	78	156	78	40	128	3,6
612009	2"	75	150	75	40	128	4,6
612020	2 1/2"	100	200	100	56	158	8,8

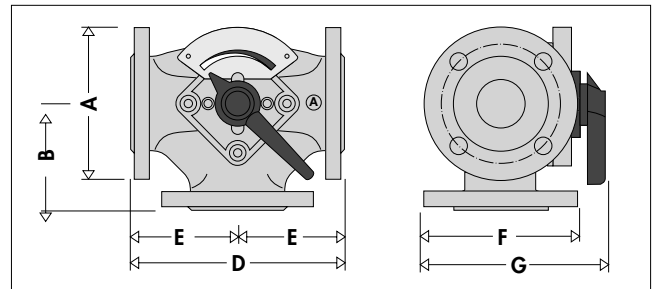

Code	A	B	D	E	F	G	Mass (kg)
612050	DN 50	90	180	90	140	190	8
612060	DN 65	100	200	100	160	210	9,6
612080	DN 80	115	230	115	190	240	13,2
612100	DN 100	130	260	130	210	260	20,3
612120	DN 125	145	290	145	240	290	26

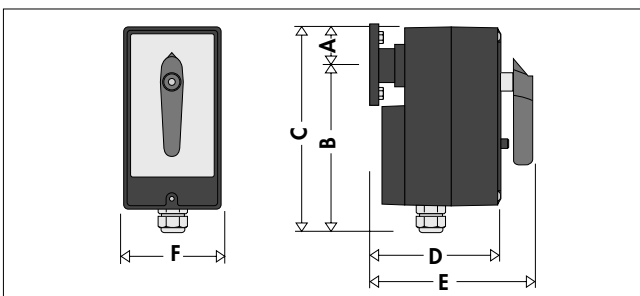

Code	A	B	C	D	E	F	Mass (kg)
63700.	25	100	125	90	112	61	0,72

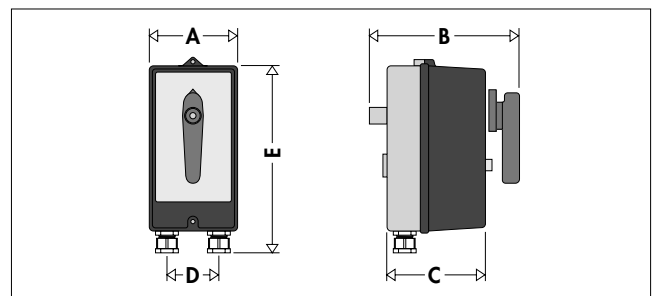

Code	A	B	C	D	E	Mass (kg)
63701.	79	130	83	44	162	1,3

Operating principle

The Caleffi 610 and 612 series valves are three-way, respectively butterfly and sector types, while the Caleffi 611 series is a four-way butterfly valve. The 610 and 612 series valves can be used both as mixing valve or as a diverter, the 611 series only as a mixing valve.

The three-way mixing valve allows simultaneous control of the primary circuit medium and of the system return medium. In particular the two mediums are mixed directly inside the valve.

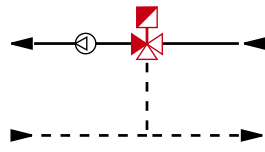

Also the four-way mixing valve allows simultaneous control of the primary circuit medium and of the system return medium. The two mediums are mixed directly inside the valve, so as to enable double circulation on both the primary and secondary circuit. The mixing valve, in this application, also performs the hydraulic separation of the primary circuit from the secondary circuit.

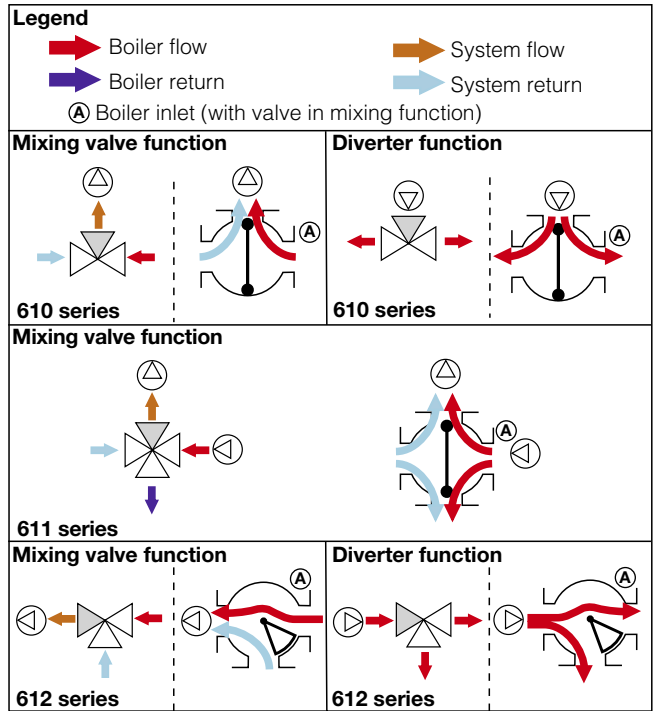
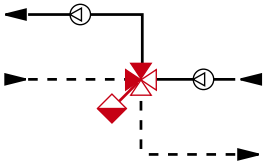

Installation example of 610 series 3-way butterfly valve with mixing valve function

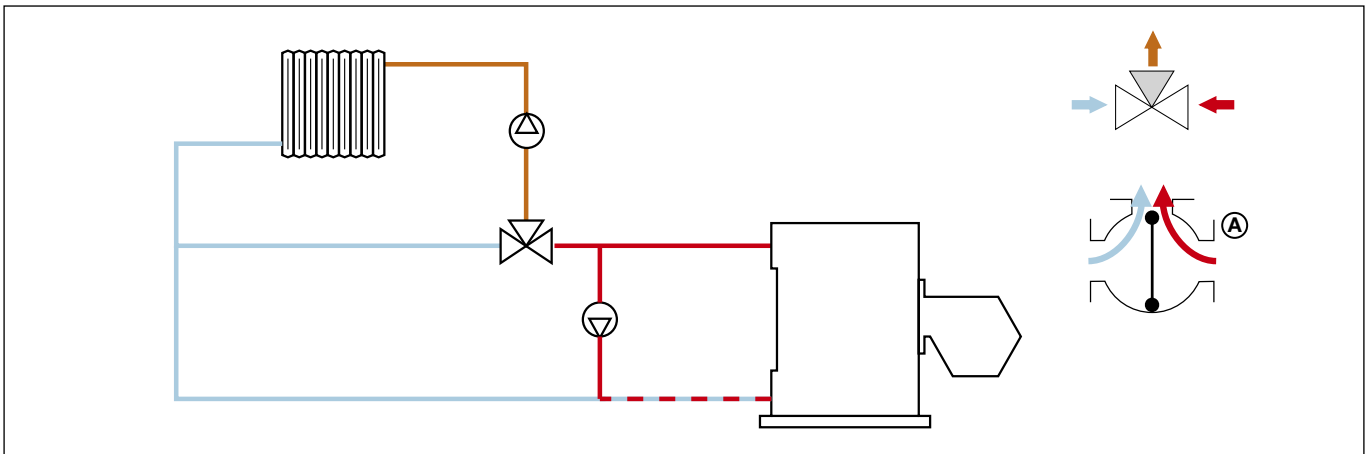

Changing the inlet position: “customized installation”

The series 610, 611 and 612 series can be used customizing the ports use:

- 1) for the 610 and 611 series it is possible to exchange the hot water inlet port from the boiler (marked with the label **A**) with the cold water inlet port returning from the system, placed on line. The mixed water outlet port remains the same in both configurations, i.e. the one positioned at 90° below the graduated plate.
- 2) for the 612 series it is possible to exchange the hot water inlet port from the boiler (marked with the label **A**) with the mixed water inlet port flowing to the system, placed on line. The cold water inlet port returning from the system remains the same in both configurations, i.e. the one positioned at 90° on the opposite of the graduated plate.

In this case it is necessary to access inside the valve body unscrewing the four hexagonal screws (fig.1), and rotating of 180° only the rotor shaped bushing (fig.2).

When customizing the ports use, we recommend removing the label **A** and marking them according to the new diagram in order to facilitate the components maintenance.

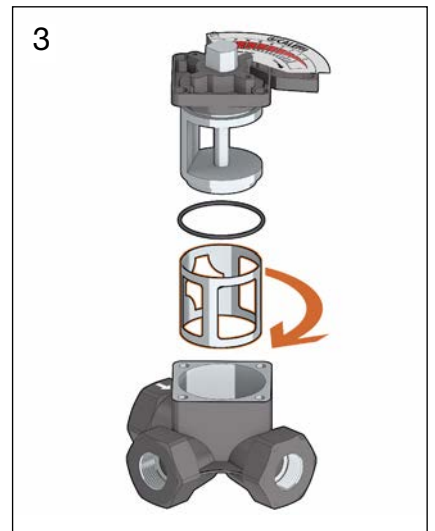
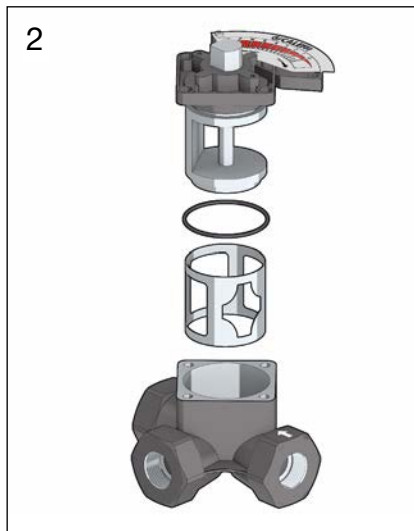
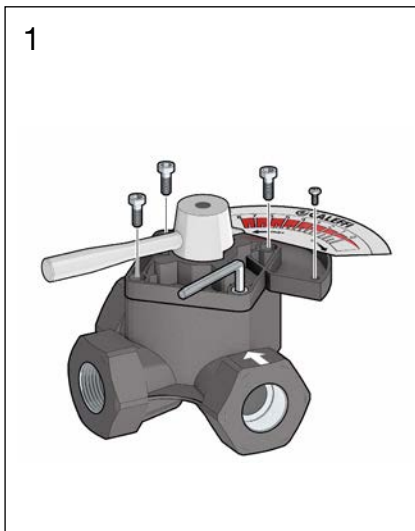
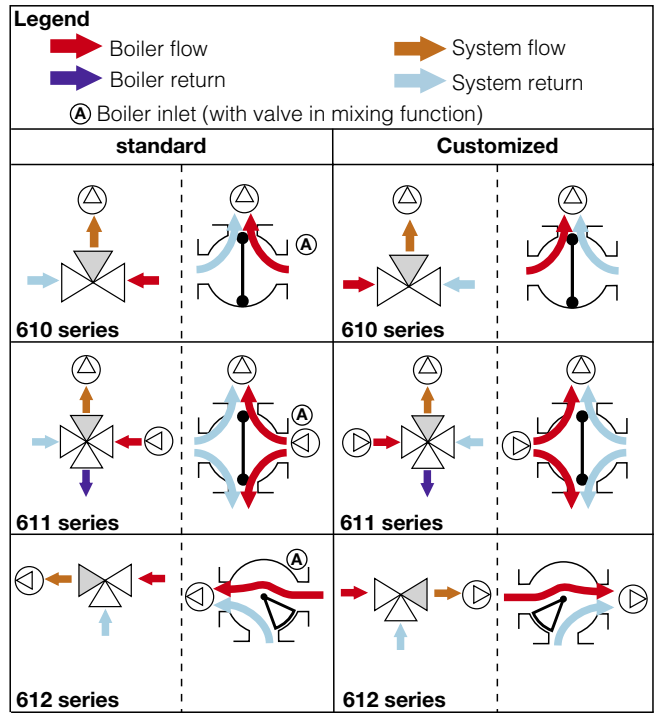

Installation example of 612 series 3-way sector valve with mixing valve function

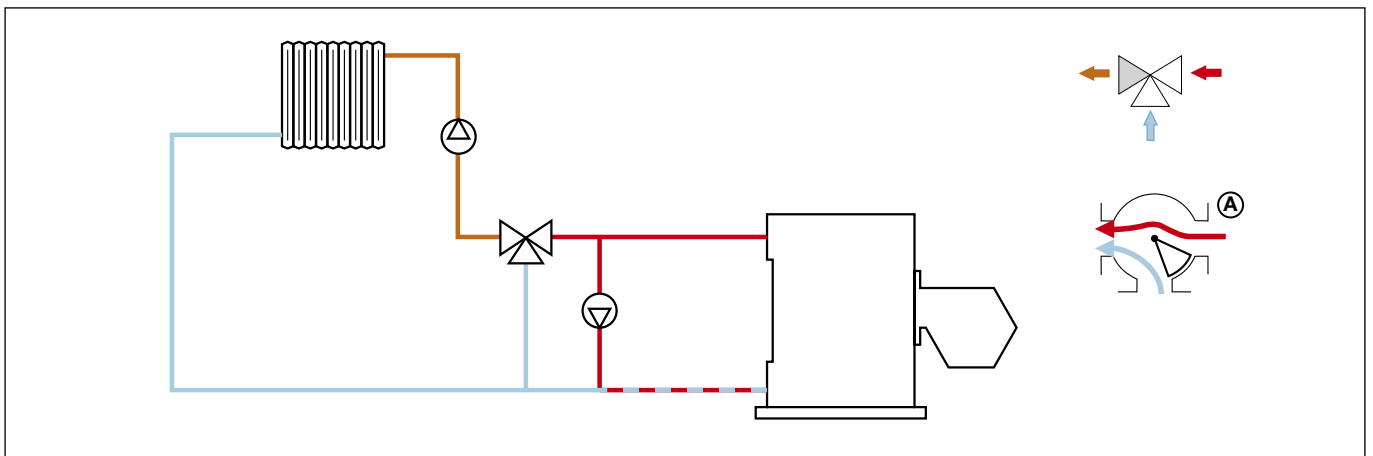

Hydraulic characteristics

610 series

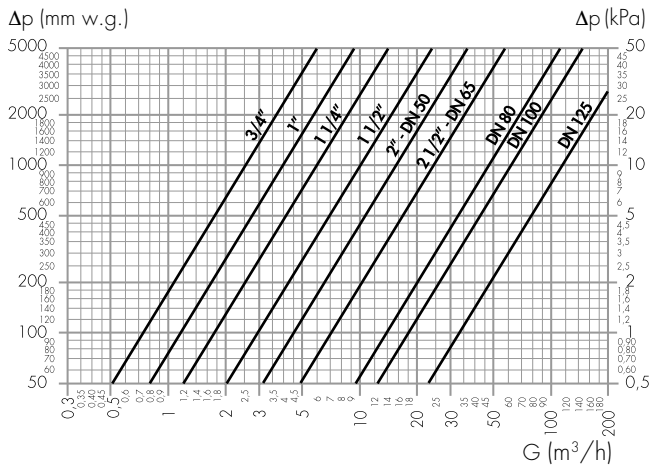

Ø	3/4"	1"	1 1/4"	1 1/2"	2"	2 1/2"
Kv (m³/h)	7,5	11,9	16,8	30	45	72
Ø	DN 50	DN 65	DN 80	DN 100	DN 125	
Kv (m³/h)	45	72	140	183	340	

611 series

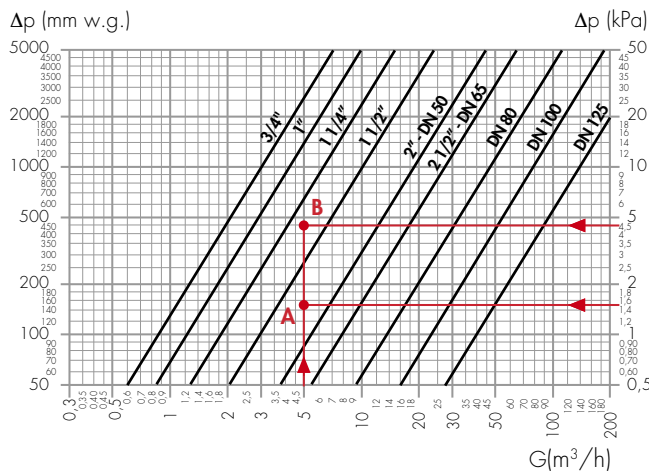

Ø	3/4"	1"	1 1/4"	1 1/2"	2"	2 1/2"
Kv (m³/h)	7,8	12,3	18,5	30	53	80
Ø	DN 50	DN 65	DN 80	DN 100	DN 125	
Kv (m³/h)	53	80	140	230	410	

612 series

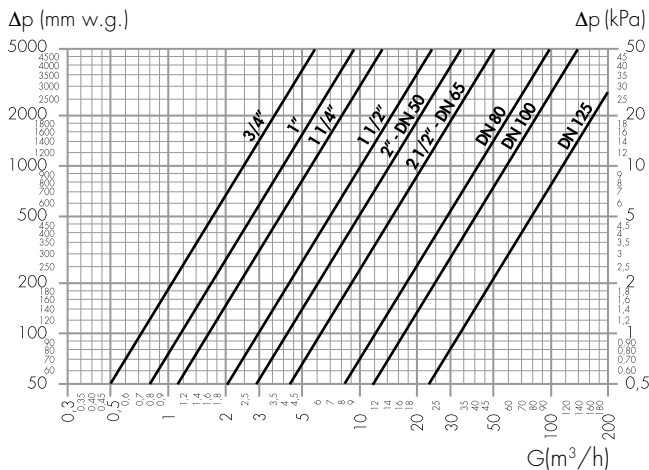

Ø	3/4"	1"	1 1/4"	1 1/2"	2"	2 1/2"
Kv (m³/h)	7,2	11,9	16,5	30	42	62
Ø	DN 50	DN 65	DN 80	DN 100	DN 125	
Kv (m³/h)	42	62	123	172	340	

Construction details

Use at high temperature

The body material, internal devices and EPDM seals make it possible to use the Caleffi 610, 611 and 612 series mixing valves in heating systems with temperatures up to 110°C.

Anti-friction system

Inside the valves, between the mixing device and the body, there is a bushing made of anti-friction material that absorbs the volume variations, if any, caused by the thermal expansion of the parts that make up the valve and ensures ease of rotation throughout the temperature range of use.

612 series linear characteristic

Thanks to the profile of the flow passage sizes obtained on the bushing, the regulation feature resulting in the system is of linear type, which is the optimal condition to guarantee the best management of the variable thermal loads on the system.

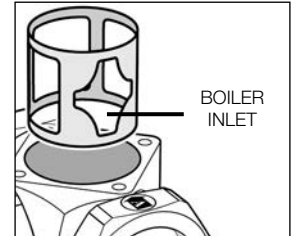

Possibility of motorization

The Caleffi 610, 611 and 612 series mixing valves are supplied with manual control but they can be motorized using the Caleffi 6370 series actuators.

Sizing method

To select the most appropriate size of the Caleffi 610, 611 and 612 series mixing valves it is necessary to know two sizes:

- the medium flow rate passing through the mixing valve
- the head loss to be attributed to the valve. Generally a loss value of 5–15% of the head loss of the circuit used is assigned to the mixing valves.

Example

Flow rate requirement:

$$G = 5 \text{ m}^3/\text{h}$$

System pipes:

$$2''$$

Head loss of the circuit used:

$$\Delta p = 3000 \text{ mm w.g.} = 30 \text{ kPa}$$

Mixing valve selection:

611 series

The mixing valve head loss Δp_V must be between 5% (Δp_{VA} , point A) and 15% (Δp_{VB} , point B) of the head loss of the circuit used:

$$\Delta p_{VA} = \Delta p \cdot 0,05 = 150 \text{ mm w.g.} = 1,5 \text{ kPa (point A)}$$

$$\Delta p_{VB} = \Delta p \cdot 0,15 = 450 \text{ mm w.g.} = 4,5 \text{ kPa (point B)}$$

Using the 611 series valve load loss diagram, the x-axis value identified is 5 m³/h and moving up vertically the A and B points are identified, which obtained at the intersection with the respective load loss values. The line joining points A and B intersects the head loss elbow of the 611 series 1 1/2" 4-way valve, which will therefore be installed on the system.

In most cases, a proper sizing leads to the choice of a valve with smaller diameter than that of the pipe to which it is installed.

Installation

Valve installation

The 610, 611 and 612 series mixing valves, installed with horizontal rotor axis, can be turned in any position, avoiding to position the actuator cable glands upwards. If instead they are installed with vertical rotor axis, the actuator must necessarily be above the valve.

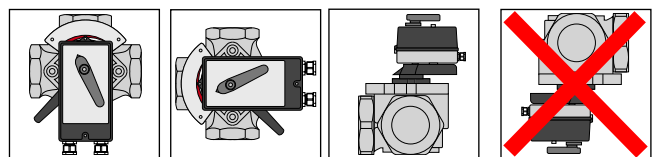

Valve motorization

For installing the 6370 series actuators to the valve, refer to the instruction sheet with the detailed information.

Wiring diagrams

Actuator
code 637002-637004
(SM50)

Actuator
1-counter clockwise rotation (CCW)
2-clockwise rotation (CW)
3-common

Auxiliary microswitch
(graphical representation at the end of the rotation indicated)
4-common
5-normally closed NC
6-normally open NO

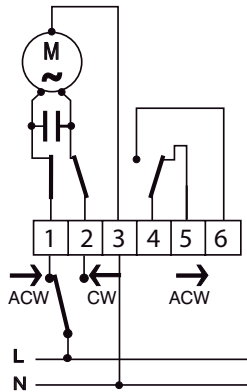

Actuator
code 637012-637014
(SM100)

Actuator
1-clockwise rotation (CW)
2-counter clockwise rotation (CCW)
3-common

Auxiliary microswitch
(graphical representation at the end of the rotation indicated)
4-normally open NO
5-normally closed NC
6-common

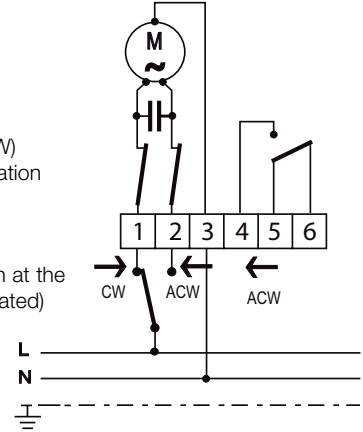

Coupling with digital regulators

Actuator code 637002 (SM50) with modulating digital regulator for heating and cooling code 161010

Electric connections

R2 CCW counter clockwise rotation
R3 CW clockwise rotation
N Neutral

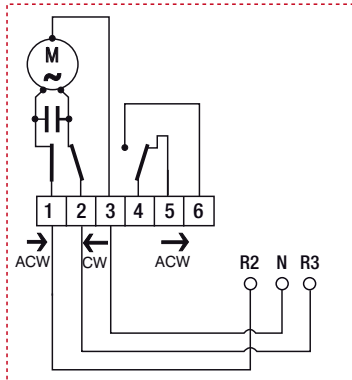

Actuator code 637012 (SM100) with modulating digital regulator for heating and cooling code 161010

Electric connections

R2 CW clockwise rotation
R3 CCW counter clockwise rotation
N Neutral

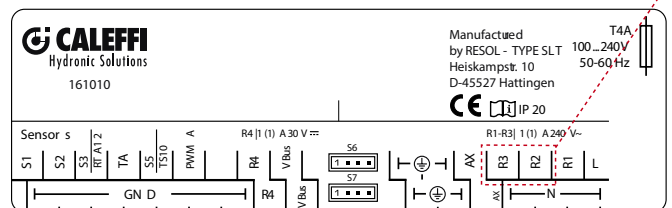
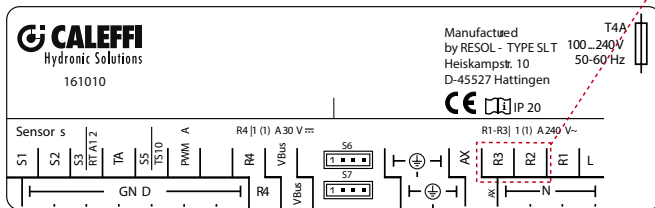
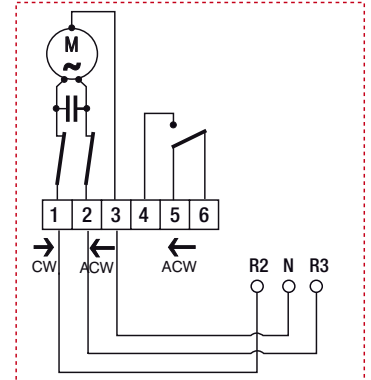

NOTE: Check the actuator rotation direction. If necessary exchange the terminals 1 and 2 of the actuator

Actuator code 637002 (SM50) with Optimiser® digital climate regulator code 152001

Electric connections

L Phase
L' Phase
1 CCW counter clockwise rotation
2 CW clockwise rotation
N Neutral

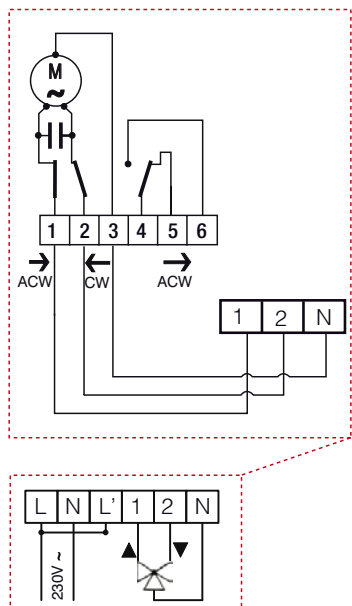

Actuator code 637012 (SM100) with Optimiser® digital climate regulator code 152001

Electric connections

L Phase
L' Phase
1 CW clockwise rotation
2 CCW counter clockwise rotation
N Neutral

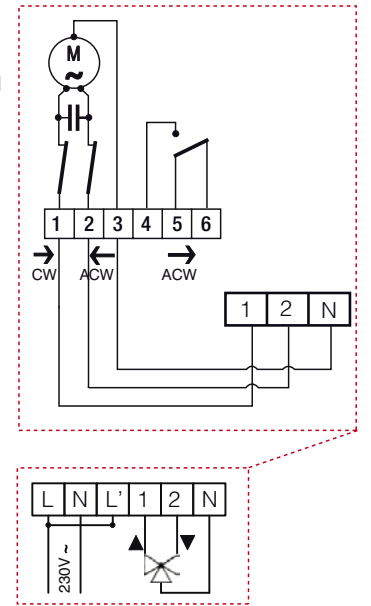

NOTE: Check the actuator rotation direction. If necessary exchange the terminals 1 and 2 of the actuator

161



Digital regulator with functional synoptic for heating and cooling complete with immersion flow probe with pocket and return probe Pt1000 Ø 6 mm. Optional climatic probe. Adjustment temperature range: 5 – 95°C. Electric supply: 230 V - 50/60 Hz. Protection class: IP 20 / EN 60529. Probe cable length: 1,5 m.



Code

161010



1520

Digital temperature controller complete with flow contact probes and outside probe. Adjustment range: 20–90°C. Electric supply: 230 V - 50/60 Hz. Protection class: IP 40.



Code

152001	with 1 channel
152002	with 2 channels
152003	with 3 channels

1520

Digital temperature controller for heating and cooling. Complete with flow probe, outside probe and relative humidity limit probe. Electric supply: 230 V - 50/60 Hz. Power consumption: 5,5 VA. Protection class: IP 40.

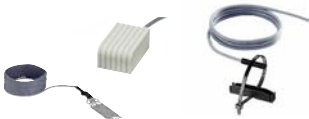

Code

152021	1 channel
---------------	-----------

6370

Actuator for mixing valves from 3/4" to 1 1/2". With auxiliary microswitch. Electric supply: 230 V or 24 V - 50 Hz. Power consumption: 3 VA. Microswitch contacts rating: 10 (2) A - 250 V (ac). Protection class: IP 42. Operating time: 60 s. With adapter.



Boiler inlet, LH side

Code	Voltage V	Motor torque (N·m)
637001	230	15
637003	24	15



6120

Three-way motorized sector mixing valve, threaded connections. Max. working pressure: 6 bar. Working temperature range: 2–110°C.

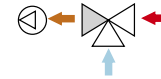

Boiler inlet, RH side

Code	Size	Voltage V	Kv (m³/h)
612025	3/4"	230	7,2
612026	1"	230	11,9
612027	1 1/4"	230	16,5
612028	1 1/2"	230	30



6120

Three-way motorized sector mixing valve, threaded connections. Max. working pressure: 6 bar. Working temperature range: 2–110°C.

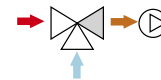

Boiler inlet, LH side

Code	Size	Voltage V	Kv (m³/h)
612015	3/4"	230	7,2
612016	1"	230	11,9
612017	1 1/4"	230	16,5
612018	1 1/2"	230	30

6370

tech. broch. 01169

Actuator for mixing valves from 3/4" to 1 1/2". With auxiliary microswitch. Electric supply: 230 V or 24 V - 50 Hz. Power consumption: 3 VA. Microswitch contacts rating: 10 (2) A - 250 V (ac). Protection class: IP 42. Operating time: 60 s. With adapter.



Code	Voltage V	Motor torque (N·m)
637002	230	15
637004	24	15

6370





tech. broch. 01169

Actuator for mixing valves from 2" to 5". With auxiliary microswitch. Electric supply: 230 V or 24 V - 50 Hz. Power consumption: 4,5 VA. Microswitch contacts rating: 16 (4) A - 250 V (ac). Protection class: IP 42. Operating time: 180 s. With adapter.



Code	Voltage V	Motor torque (N·m)
637012	230	35
637014	24	35

Application diagrams

-  Shut-off valve
-  Pump
-  Temperature probe
-  Pressure gauge
-  Thermometer

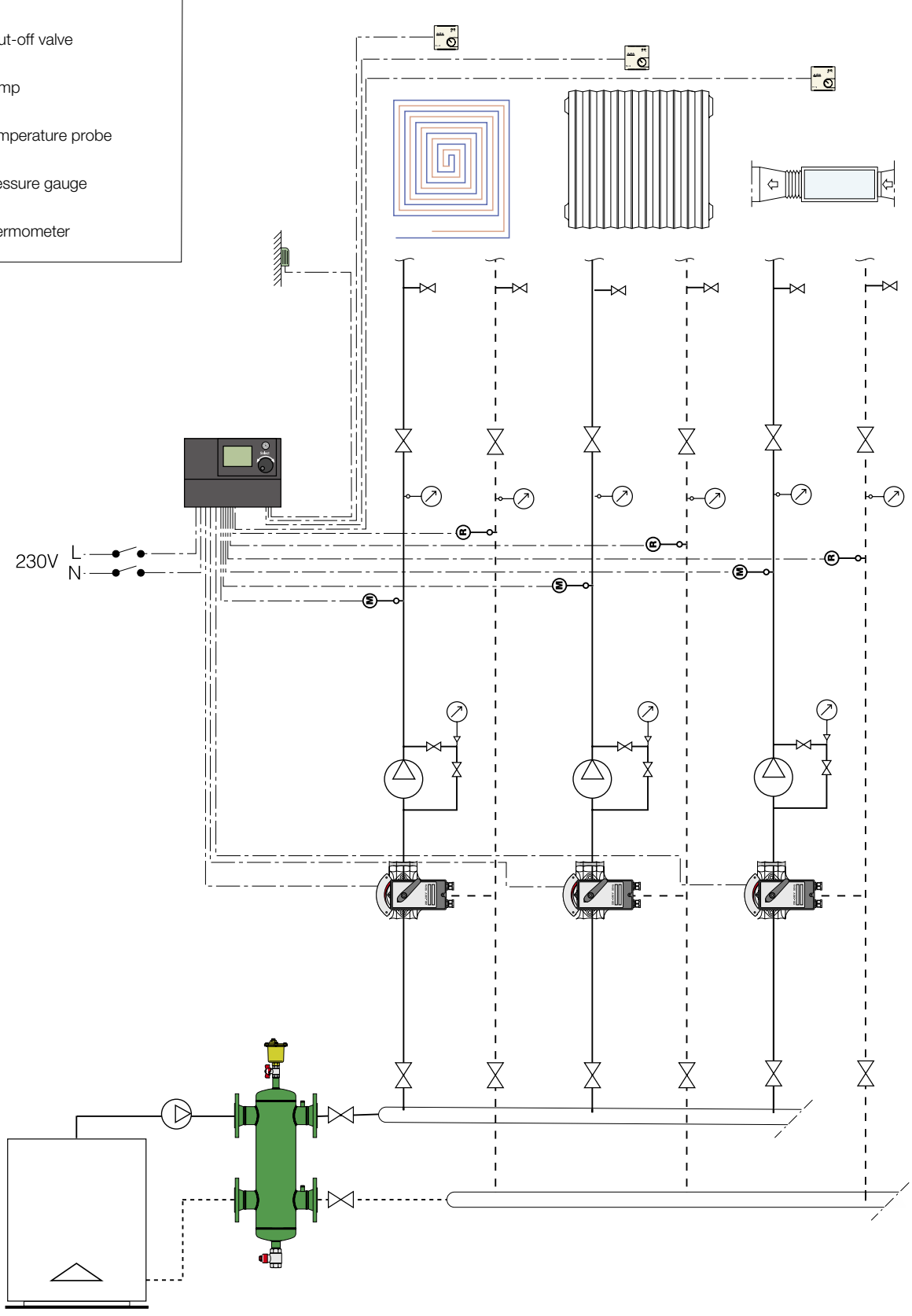

 Outside probe

 Shut-off valve

 Pump

 Temperature probe

 Pressure gauge

 Thermometer

 Summer/Winter Mode Selector

 Safety thermostat

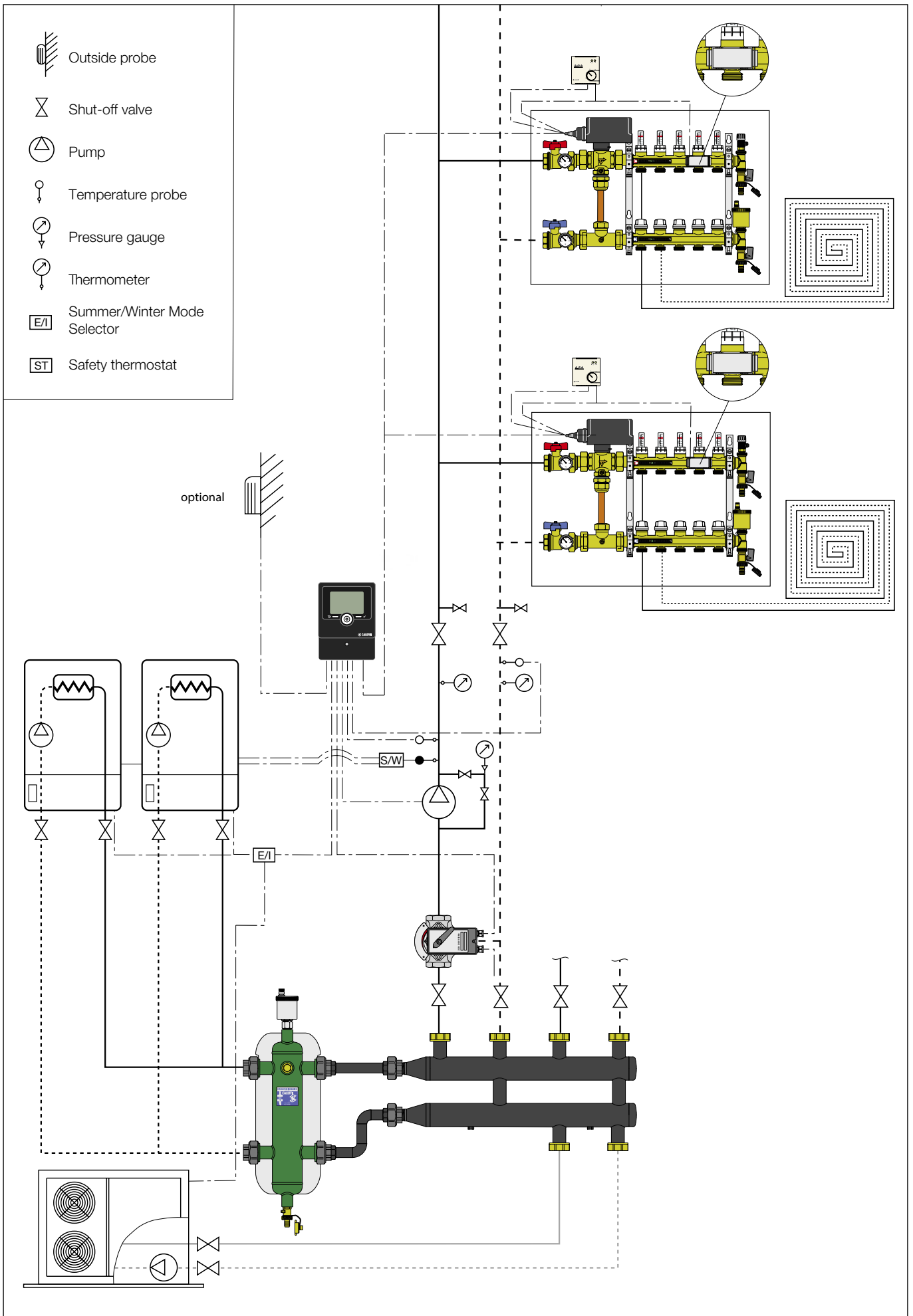

SPECIFICATION SUMMARY

610 series

Three-way butterfly mixing valve with manual control. Heavy series. Threaded 3/4" F connections (3/4"-2 1/2"). Flanged DN 50 (DN 50-DN 125) connections. Coupling with counterflange EN 1092-1. Cast iron body and rotor. Aluminium cover. Lever in PA66GF30. EPDM seals. Medium: water, glycol solutions. Maximum percentage of glycol 30%. Temperature range 2-100°C. Maximum working pressure 6 bar. Can be motorized.

611 series

Four-way butterfly mixing valve with manual control. Heavy series. Threaded 3/4" F connections (3/4"-2 1/2"). Flanged DN 50 (DN 50-DN 125) connections. Coupling with counterflange EN 1092-1. Cast iron body and rotor. Aluminium cover. Lever in PA66GF30. EPDM seals. Medium: water, glycol solutions. Maximum percentage of glycol 30%. Temperature range 2-100°C. Maximum working pressure 6 bar. Can be motorized.

612 series

Three-way sector mixing valve with manual control. Heavy series. Threaded 3/4" F connections (3/4"-2 1/2"). Flanged DN 50 (DN 50-DN 125) connections. Coupling with counterflange EN 1092-1. Cast iron body and rotor. Aluminium cover. Lever in PA66GF30. EPDM seals. Medium: water, glycol solutions. Maximum percentage of glycol 30%. Temperature range 2-100°C. Maximum working pressure 6 bar. Can be motorized.

6370 series

Actuator for 3/4" (3/4"-5") mixing valves. Three point type regulation. Electric supply 230 V (ac) or 24 V (ac). Power consumption 3 VA (3/4"-1 1/2"), 4,5 VA (2"-5"). Dynamic torque 15 N·m (3/4"-1 1/2") 35 N·m (2"-5"). Operating time 60 seconds (3/4"-1 1/2") 180 s (2"-5"). Protection class IP 42. Maximum ambient temperature 55°C. Equipped with auxiliary microswitch, contact rating 10 (2) A - 250 V (ac) (3/4"-1 1/2"), 16 (4) A - 250 V (ac) (2"-5").

Code 161010

Digital regulator with functional synoptic for heating and **cooling**. Electric supply 230 V - 50/60 Hz. Three-point type. Power consumption 3 VA. Adjustment working temperature range 5-95°C. Protection class IP 20/EN 60529. Complete with flow/return Pt 1000 probes and contact probe holder. Probes flow/return working range -50-180°C. Two-wire cable with pocket connection 1/8" M connection, length 1,5 m.

1520 series

OPTIMISER® digital climate regulator. Electric supply 230 V (ac), ±10%; 50/60 Hz. Power consumption 5,5 VA. Output signals for 3 relay contacts for code 152001, 6 relay contacts for code 152002, 10 relay contacts for code 152003. Contact rating 250 V (ac), 8 (2) A (max 9 A in total). Protection class II. Protection class IP 40. Ambient temperature range 0-40°C. Storage temperature range -20-70°C. Maximum permissible humidity Class F according to DIN 40040. Settable mixing valve rotation time from 10 to 900 s. Data storage with no power supply one year. RS 232 remote reading. Clock operating life with no power supply 4 hours. Minimum SP function changeover time 10 min. Sizes: 180 x 130 x 60 mm.

Code 152021

OPTIMISER® digital climate controller for heating and heating/**cooling**. Electric supply 230 V (ac), ±10%; 50/60 Hz. Power consumption 5,5 VA. Output signals: 3 heating relay contacts 6 heating/**cooling** relay contacts. Contact rating 50 V (ac), 8 (2) A (max 9 A in total). Protection class II. Protection class IP 40. Ambient temperature range 0-40°C. Storage temperature range -20-70°C. Maximum permissible humidity class F according to DIN 40040. Settable mixing valve rotation time from 10 to 900 s. Data storage with no power supply one year. Remote reading via minidin RS 232 connection. Clock operating life with no power supply 4 hours. Minimum SP function changeover time 10 min. Sizes: 180 x 130 x 60 mm.

Code 161002

Outside compensated temperature probe.

Code 161004

Dew point detector. Working temperature range: 30-100 RH%.

We reserve the right to make changes and improvements to the products and related data in this publication, at any time and without prior notice.